

1 2 3 4 5 6

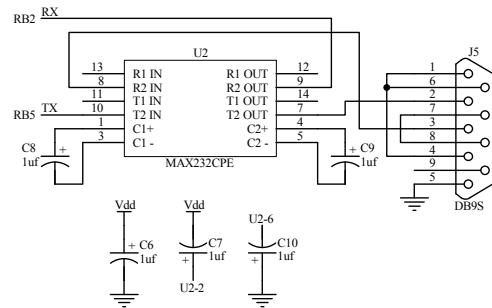
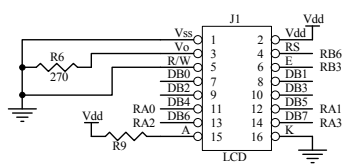
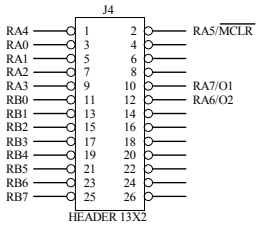
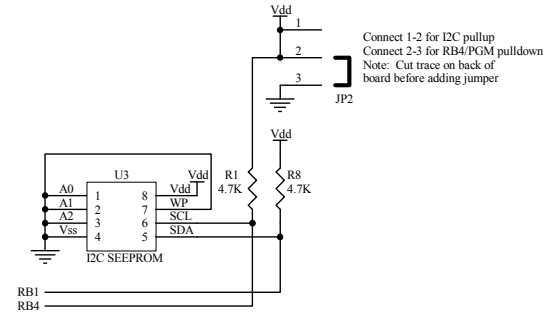
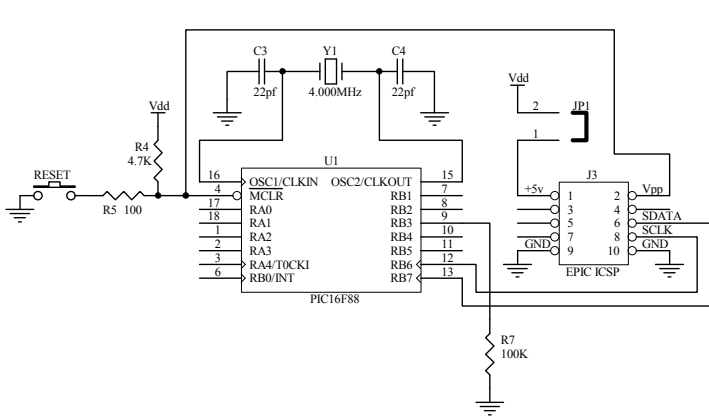
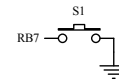
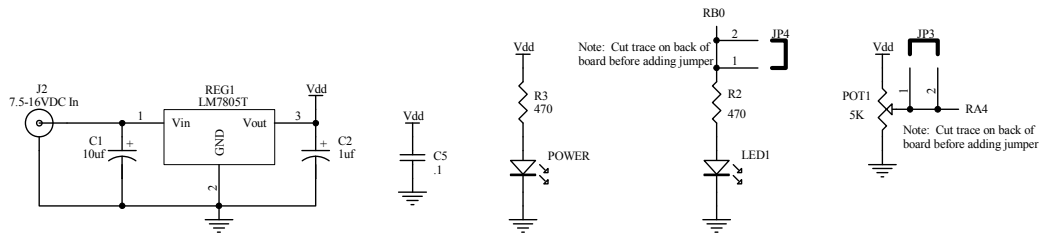

Title		LAB-X18 Schematic		Copyright 2006 microEngineering Labs, Inc.	
Size	Number	06018		Revision	
B				A	
Date:	13-Sep-2006		Sheet 1 of 1		
File:	C:\pfiles\labx18.sch		Drawn By: JMS		

1 2 3 4 5 6